

Power factor correction components

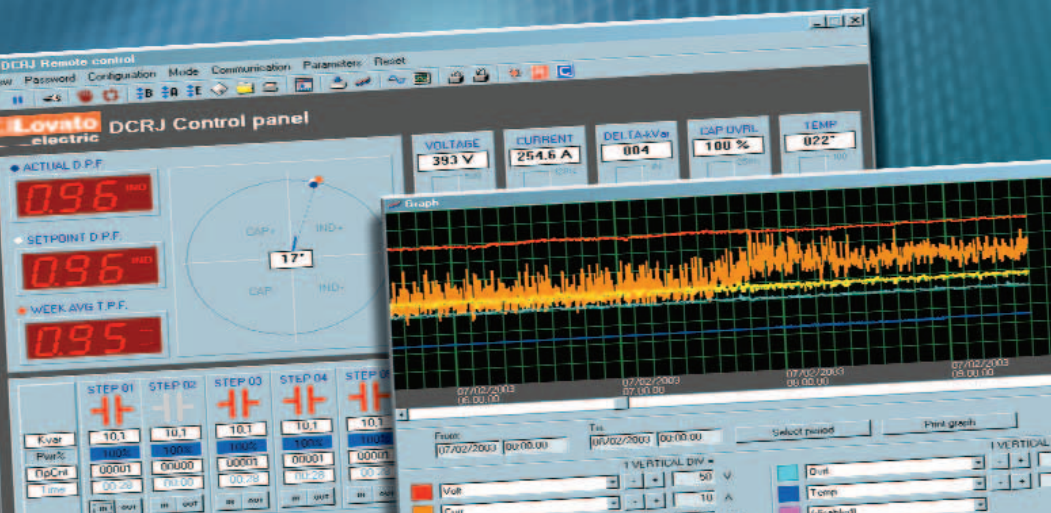

- Planet-SWITCH
- Planet-DIN
- Planet-LOGIC

Lovato
electric
100% electricity

Power factor correction components

Automatic power factor regulators



DCRK

- Digital programming
- 5 or 7 step configuration in 96x96mm housing
- 8 or 12 step configuration in 144x144mm housing
- Capacitor overload protection
- Internal overheating protection
- TTL/RS232 serial port
- Automatic set-up function (adjustable)
- Configurable alarms.



DCRJ

- Digital programming
- 8 or 12 step configuration in 144x144mm housing
- Separate voltage measurement input
- Capacitor overload protection
- Internal-external overheating protection
- RS232 programming and supervision interface
- Automatic set-up function (adjustable)
- Configurable alarms
- Voltage and current harmonics measurement
- Event log
- Suitable for medium voltage systems.

DESCRIPTION	DCRK	DCRJ
Front plate		
3-digit display	●	●
4-digit display supplement		●
4 operation keys	●	●
1 function key		●
7 LED indicators for main functions and measurement	●	
14 LED indicators for main functions and measurement		●
Control - Functions		
Automation recognition of current flow	●	●
4-quadrant operation	●	●
Separate voltage input		●
Three-phase voltage control		●
Medium-voltage usage		●
Phase-Neutral connection in 3-phase systems		●
Temperature sensor supplement input		●
TTL/RS232 communications interface	●	
RS232 communications interface		●
Automatic set-up function (adjustable)	●	●
Set-up and automatic panel test software	●	●
Isolated RS435 serial port		●
Remote supervision software		●
Measurements		
Instantaneous power factor displacement (cos-phi)	●	●
Instantaneous and average weekly power factor	●	●
Voltage and current	●	●
Reactive power to reach set-point value	●	●
Total reactive power	●	●
Capacitor overload	●	●
Electric panel temperature	●	●
Maximum voltage and current value	●	●
Maximum capacitor overload value	●	●
Maximum panel temperature value	●	●
Maximum capacitor temperature value	●	●
Active and apparent power	●	
Current and voltage harmonic analysis	●	
Current and voltage harmonic waveform logged at overload events		●
Step "var" value		●
Number of switching per step		●
Protections		
Voltage too high and too low	●	●
Current too high and too low	●	●
Over compensation (capacitors disconnected and cosf-phi higher than set-point)	●	●
Under compensation (capacitors connected and cosf-phi lower than set-point)	●	●
Capacitor overload	●	●
Capacitor overload on all 3 phases		●
Over temperature	●	●
No-voltage release protection	●	●
Capacitor bank malfunction		●
Over maximum harmonic distortion level limit		●
Alarm property variation (enable, trip delay, relay energising, etc.)	●	●

Power factor correction components

Automatic power factor regulators

DCRK Series



DCRK5 and 7



DCRK8 and 12

Order code	Steps	Flus-mount housing size	Qty per pkg	Weight
	n°	[mm]	n°	[kg]
DCRK 5	5	96x96	1	0.365
DCRK 7	7	96x96	1	0.375
DCRK 8	8	144x144	1	0.640
DCRK 12	12	144x144	1	0.660

Software

Order code	Description	Qty per pkg	Weight
		n°	[kg]
DCRK SW	Set-up and automatic test software complete with cable 51 C11	1	0.246

Accessories and spare parts

51 C11	PC-DCRK connecting cable for TTL/RS232 communication port, 2.8 m long	1	0.090
31 PACR	Front protective cover for DCRK8 and DCRK12 types. IP54	1	0.107

Example of main window frame using DCRK SW

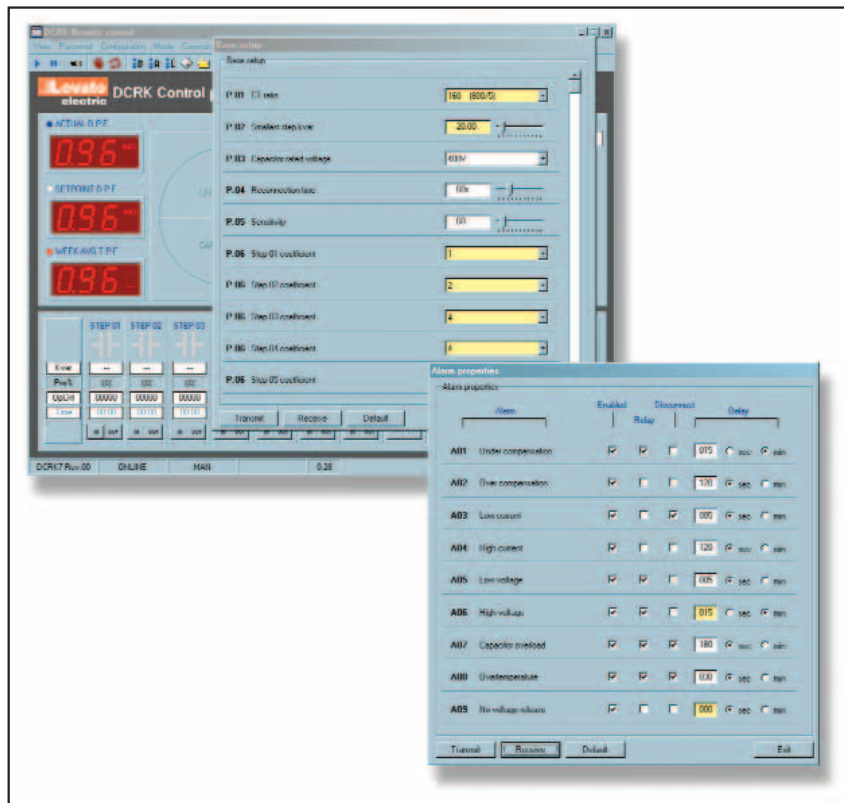

General characteristics

- Digital microprocessor regulator for automatic power factor correction systems with output relays for the connection and disconnection of capacitor banks
- 5, 7, 8 and 12 step versions, the last two of which are programmable as alarm and/or fan control
- For co-generation systems; 4 quadrant operation
- Accurate and reliable power factor control of a system even in presence of high current and voltage harmonic content
- Warrants optimal capacitor use for increased life using rational control of the capacitor operation and connection time
- RMS voltage and current measurements
- Average weekly power factor measurement (last 7 days)
- Adjustable tripping sensitivity, integral switching time
- Adjustable reconnection time delay
- No-voltage release protection
- Protection against capacitor overload and panel overheating
- Automatic set-up function (adjustable)
- TTL-RS232 interface with personal computer for: fast set-up, function and alarm customising and automatic electric panel testing
- Installation ease with the use of one external current transformer only.

Operational characteristics

- Voltage circuit
 - Supply and control voltage U_e : 380-415VAC
 - 220-240VAC or 415-440VAC on request
 - Rated frequency: 50/60Hz $\pm 1\%$ self configurable
 - Power consumption: 5.8VA (DCRK5 and DCRK7)
 - 4.2VA (DCRK8 and DCRK12)
- Current circuit
 - Rated current I_e : 5A (1A on request)
 - Operation range: 0.125-6A
 - Overload peak: 20 I_e for 10ms
 - Power consumption: 0.64VA
- Measurements and controls
 - Power factor adjustment: 0.8 inductive - 0.8 capacitive
 - Voltage measurement range: -15% to $+10\%$ U_e
 - Current measurement range: 2.5-120% I_e
 - Temperature measurement range: -40 to $+100^\circ\text{C}$
 - Capacitor overload current range: 0-250%
 - Type of voltage and current measurement: RMS
 - Reconnection time of same step: 5-240s
 - Tripping sensitivity: 5-600s/step
- Output relays
 - 5, 7, 8 or 12 steps, the last of which is isolated
 - Contact configuration: Normally Open (NO); the last contact of DCRK8-DCRK12 is a changeover type
 - Rated current I_{th} : 5A 250VAC (AC1)
 - Maximum capacity of common terminal: 12A
 - Rated operational voltage: 250VAC
 - IEC/EN 60947-5-1 contact designation: C/250, B/400
 - Maximum switchable voltage: 440VAC
- Housing
 - Flush mounting
 - Degree of protection on front: IP54 for DCRK5 and DCRK7. IP41 for DCRK8 and DCRK12 (IP54 with protective cover 31 PACR)
- Operating temperature: -20 to $+60^\circ\text{C}$
- Connection
 - Type of terminal: plug-in
 - Maximum cable section: 2.5mm²; AWG 12.

Certifications and compliance

Certifications obtained: cULus pending.
Compliant with standards: IEC/EN 61010-1, IEC/EN 61000-6-2, CISPR 11/EN 55011.

Power factor correction components

Automatic power factor regulators

DCRJ series



DCRJ8 and 12

Order code	Steps	Flus-mount housing size	Qty per pkg	Weight
	n°	[mm]	n°	[kg]
DCRJ 8	8	144x144	1	0.670
DCRJ 12	12	144x144	1	0.690

Software

Order code	Description	Qty per pkg	Weight
		n°	[kg]
DCRJ SW	Set-up, automatic test and remote control software complete with cables 51 C2 and 51 C4	1	0.246

Accessories and spare parts

51 C2	PC-DCRJ connecting cable, 1.8 m long	1	0.090
51 C4	PC-RS232/RS485 converter drive connection cable, 1.8 m long	1	0.147
4 PX1	RS232/RS485 converter drive, galvanically isolated, 220-240VAC or 110-120VAC	1	0.600
NTC 01	Temperature sensor	1	0.150
31 PACR	Front protective cover. IP54	1	0.107

① RS232/RS485 opto-isolated converter drive, 38,400 Baud-rate maximum, automatic or manual TRANSMIT line supervision, 220...240VAC ±10% supply (110-120VAC supply obtainable by modifying device jumpers).

General characteristics

- Digital microprocessor regulator for automatic power factor correction systems with output relays for the connection and disconnection of capacitor banks
- 8 and 12 step versions, the last two of which are programmable as alarm and/or fan control
- For systems of medium-voltage (separate voltage input) and co-generation (4 quadrant operation)
- Accurate and reliable power factor control of a system even in presence of high current and voltage harmonic content
- Warrants optimal capacitor use for increased life using rational control of the capacitor operation and connection time
- RMS voltage and current measurements
- Measurement of average weekly power factor (last 7 days), capacitor overload, electric panel temperature, voltage and current harmonic content
- Event viewing of harmonic overload limit exceeded only
- Harmonic content analysis of logged events complete with relative waveforms
- Adjustable tripping sensitivity, integral switching time
- Adjustable reconnection time delay
- Micro-breaking protection, no-voltage release protection
- Protection against capacitor overload and panel overheating
- Measurement of temperature
- Connection to external NTC 01 sensor
- Automatic set-up function (adjustable)
- RS232/RS485 serial ports
- Remote supervision software for personal computer interface and supervision for: fast set-up, function and alarm customising and automatic electric panel testing
- Installation ease with the use of one external current transformer only.

Operational characteristics

- Supply circuit
 - Dual supply voltage Ue: 110-127 / 220-240VAC
 - Rated frequency: 50/60Hz ±1% self configurable
 - Power consumption: 5VA
- Voltage circuit
 - Three phases without neutral
 - Operating range: 85-760VAC
 - Rated frequency 50/60Hz ±1%, self configurable
- Current circuit
 - Rated current Ie: 5A (1A on request)
 - Operation range: 0.125-6A
 - Overload peak: 20Ie for 10ms
 - Power consumption: 0.27VA
- Measurements and controls
 - Type of voltage and current measurement: RMS
 - Voltage measurement range: 100-690VACVAC
 - Current measurement range: 2.5-120% Ie
 - Temperature measurement range: -30 to +100°C
 - Capacitor overload current range: 0-250%
 - Power factor adjustment of which: 0.8 inductive - 0.8 capacitive
 - Reconnection time of same step: 5-240s
 - Tripping sensitivity: 5-600s/step
- Output relays
 - 8 or 12 steps, the last of which is isolated
 - Contact configuration: Normally Open (NO); the last of which is a changeover type
 - Rated current Ith: 5A 250VAC (AC1)
 - Maximum capacity of common terminal: 12A
 - Rated operational voltage: 250VAC
 - IEC/EN 60947-5-1 contact designation: C/250, B/400
 - Maximum switchable voltage: 440VAC
- Housing
 - Flush mounting
 - Degree of protection on front: IP41; IP54 with protective cover 31 PACR.
- Operating temperature: -20 to +60°C
- Connection
 - Type of terminal: plug-in
 - Maximum cable section: 2.5mm²; AWG 12.

Certifications and compliance

Certifications obtained: cULUS pending.
Compliant with standards: IEC/EN 61010-1, IEC/EN 61000-6-2, CISPR 11/EN 55011.

Example of main window frame using DCRJ SW

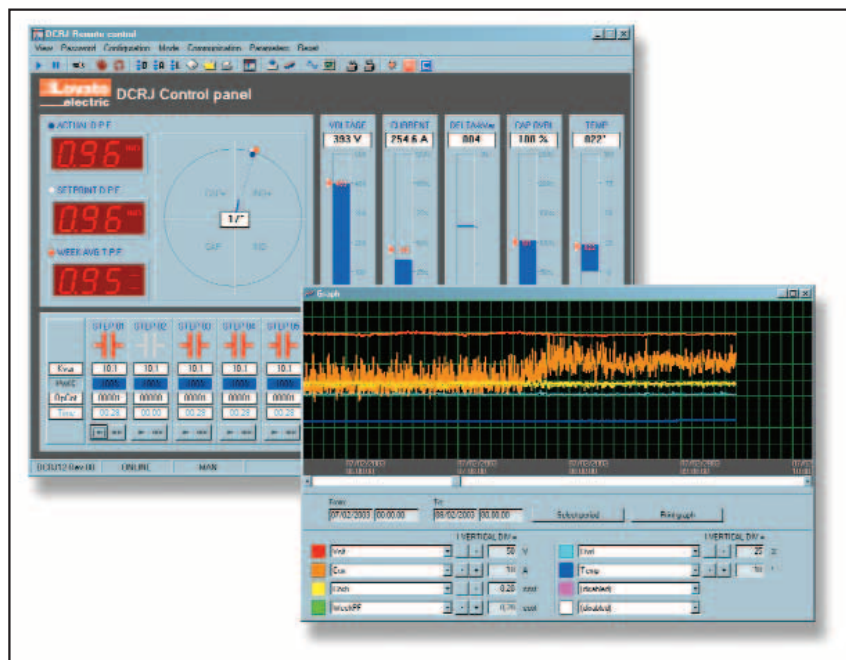

Power factor correction components

Contactors for power factor correction with control circuit: AC

BF...K contactors (including limiting resistors)



11 BF..K...

Order code	Maximum operating power at ①				Qty per pkg	Wt
	230V	400V	440V	690V		
	[kvar]	[kvar]	[kvar]	[kvar]	n°	[kg]
AC coil.						
11 BF9K 10 ②③	4.5	8	9	10	10	0.490
11 BF12K 10 ②③	7	12.5	14	16	10	0.490
11 BF20K 00 ②④	9	15	17	20	10	0.530
11 BF25K 00 ②④	11	20	22	22	10	0.530
11 BF40K 00 ②④	17	30	33	36	10	0.660
11 BF50K 00 ②④	22	38	41	46	5	1.440
11 BF65K 00 ②④	26	45	50	56	5	1.470
11 BF80K 00 ②④	34	60	65	70	5	1.470

- ① Consult our Customer Service (Tel. +39 035 4282422) for the use at contactors to switch with delta connection.
- ② Complete order code with the coil voltage digit (if 50Hz) or with the voltage digit followed by 50-60 (if 50-60Hz frequency) or with the voltage digit followed by 60 (if 60Hz).
Standard voltages are as follows:
- 50Hz 24-48-110-220-230-240-380-400-415V
- 50/60Hz 24-48-110-220-230-230-240-380-380/400-415V
- 60Hz 24-48-110-120-220-230V.
Other voltages available on request.
- ③ One NO auxiliary contact incorporated.
- ④ No auxiliary contact incorporated.

Operational characteristics

Type	Rated current	Fuse gG
	[A]	[A]
BF9 K	12	16
BF12 K	18	25
BF20 K	23	40
BF25 K	30	40
BF40 K	43	63
BF50 K	58	80
BF65 K	70	100
BF80 K	90	125

Ambient operating temperature: $\leq 50^{\circ}\text{C}$. For ambient temperatures higher than 50°C and up to 70°C , the maximum operating power values indicated in the table must be reduced by a percentage equal to the difference between the operating ambient temperature and 50°C .

E.g.: Using a BF25K 00 contactor at the ambient temperature of 60°C , the maximum operating power (at 400V) of the contactor will be equal to $20 \text{ kvar} - 10\% = 18 \text{ kvar}$.

Operating cycle: ≤ 120 cycles/h.
Electrical life: $\geq 200,000$ cycles.

Certifications and compliance

Certification obtained: cULus.
Compliant to standards: IEC/EN 60947-4-1.

Kits to assemble BF...K contactors

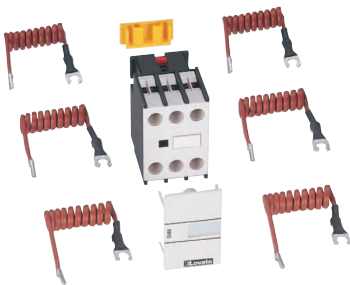

11 G46...

Order code	For contactor	Qty per pkg	Wt
		n°	[kg]
11 G460	BF9 10 - BF12 10 - BF20 00 BF25 00 - BF40 00	1	0.072
11 G464	BF50 00 - BF65 00 - BF80 00	1	0.120

To optimise contactor stock management, a kit is available to transform normal three-pole contactors into BF.K types for power factor correction. The table to the left indicates which kits to purchase depending on the standard contactor in stock.

Power factor correction components

Dimensions and wiring diagrams

DCRK5 - DCRK7

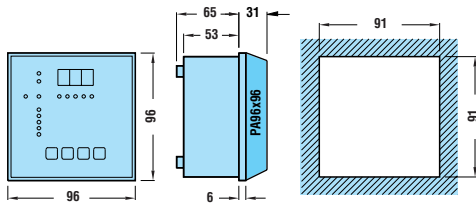

DCRK8 - DCRK12 - DCRJ8 - DCRJ12

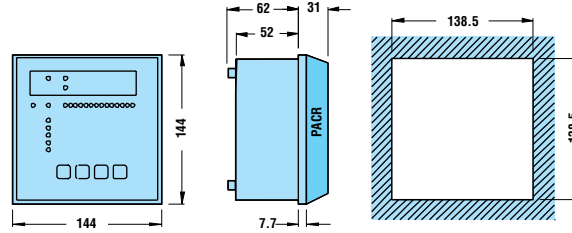

BF9K... - BF12K...

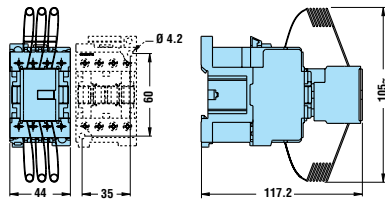

BF20K... - BF25K...

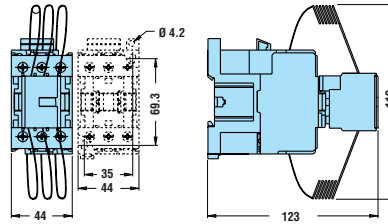

BF40K..

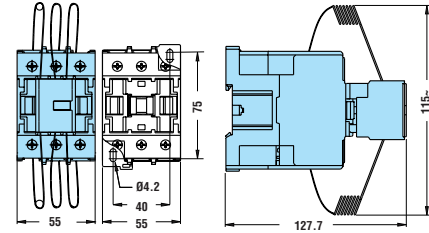

BF50K.. - BF65K.. - BF80K..

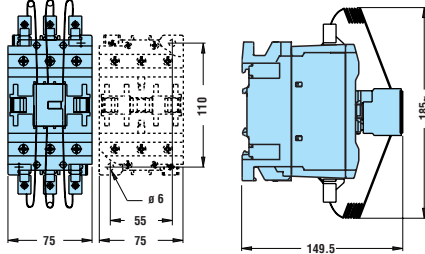

DCRK... installed with BF...K contactors

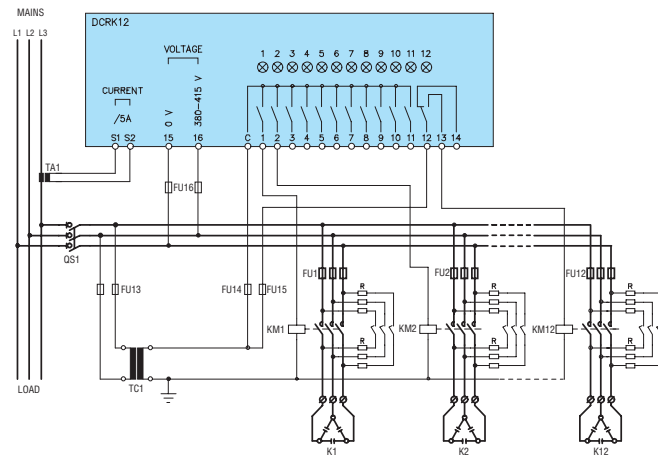

DCRJ... installed with BF...K contactors

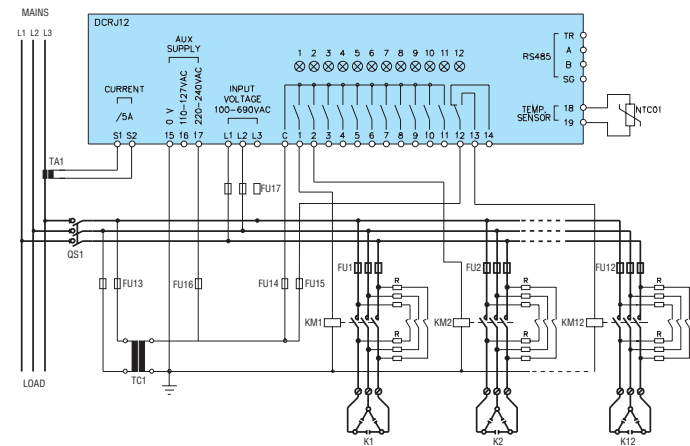

IMPORTANT

- For three phase connection, the voltage input must be connected between two phases; the line current transformer must be connected to the remaining phase.
- The polarity of the current input is irrelevant.
- When no auxiliary source is available, the line to be controlled (maximum 240VAC) can supply the regulator.

CAUTION! Always remove the power supply when operating on the terminals.

BF9K - BF12K

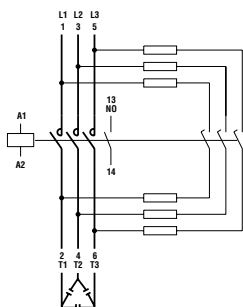

BF20K - BF25K - BF40K - BF50K BF65K - BF80K

